

Side-by-side comparison of the beloved vintage Truespoke hub and the modern Truespoke.
Both hubs have similar looks and style but there are many important differences.



Modern Truespoke Hub

Structurally, the modern Truespoke hub on the left, is much heavier and thicker than the vintage hub. All edges are much smoother and defined.

An original Truespoke hub is shown below. Notice how thin the steel hub material is compared to the modern Truespoke on the left. The oblong stud holes are what is known as a "Uni-lug" bolt pattern which was dropped in the modern hub due to vibration and difficulty with the oblong washers. The vintage Truespoke was hand-welded together from three pieces. The modern Truespoke is made of one-piece forged steel and is much stronger.



Vintage Truespoke Hub



This photo shows the dramatic difference between the modern Truespoke forged hub on the left and the original Truespoke 3-piece welded hub. The modern Truespoke has a single bolt-pattern unlike the vintage hub which uses the old style "Uni-lug" stud holes.

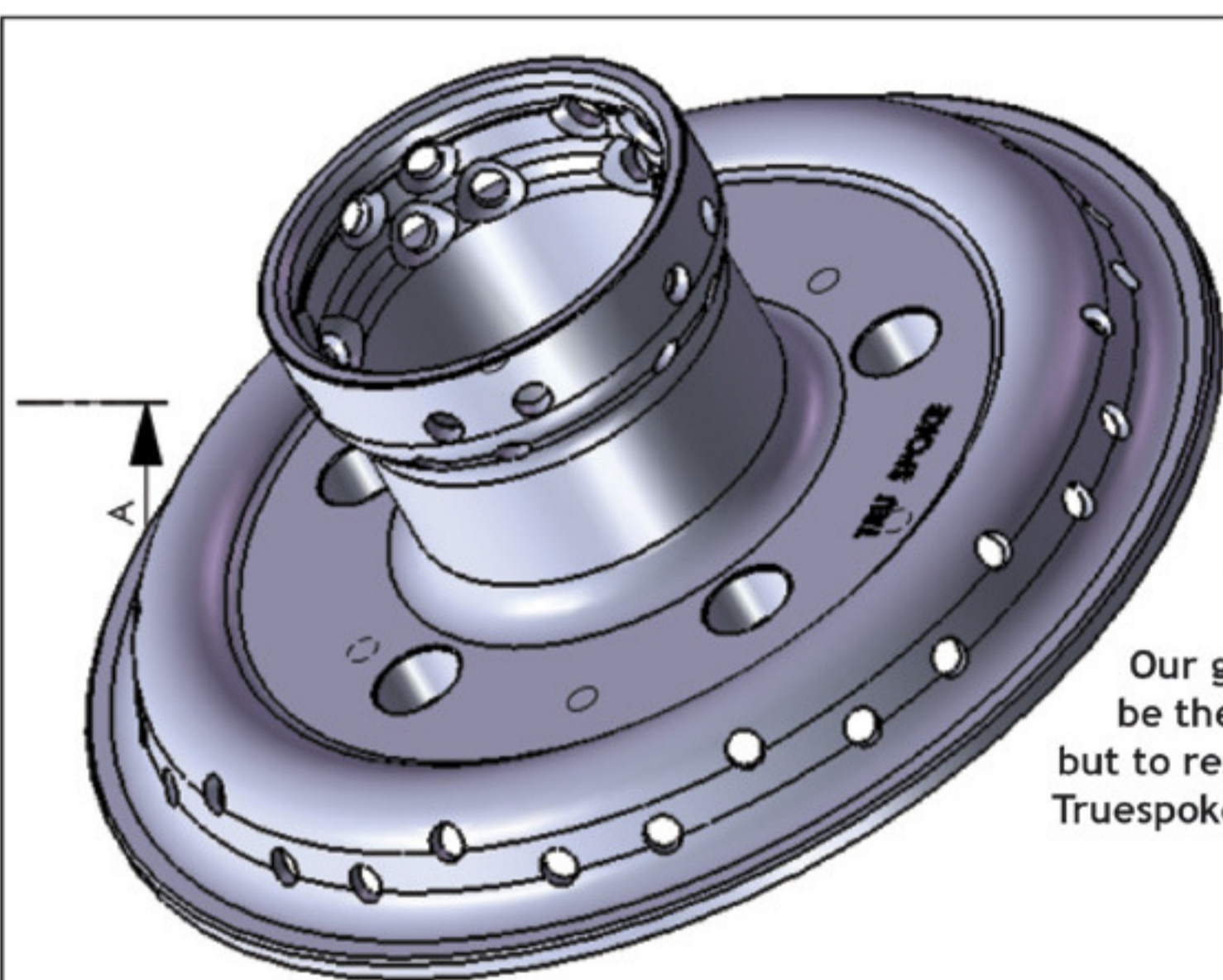

Hundreds of hours of engineering and design went into creating the modern Truespoke hub. Numerous prototypes were built and tested before the final design was selected. The use of the CAD/CAM computer drawings and scientific construction methods permitted Truespoke to re-invent the classic Truespoke wheel.

Our goal was to have the modern Truespoke be the state-of-the-art for the next 50 years but to respect tradition and keep that fantastic Truespoke style alive. Mission accomplished!

Counter-sunk spoke holes allow for a higher degree of precision in the assembly of the wheel. More accurate tolerances contribute to the excellent ride characteristics of this wire wheel and also make the wheel easier to balance.

The tube-wall thickness has been increased in the modern Truespoke over the old models for added strength and safety.

Show-quality polishing and multi-layer chrome plating result in matchless jaw-dropping beauty.

Hub edges are smooth and have been polished for a jeweler-quality brilliance. Truespoke sets the standard in wire wheels. No wonder why Truespoke has been America's favorite wire wheel since 1974.

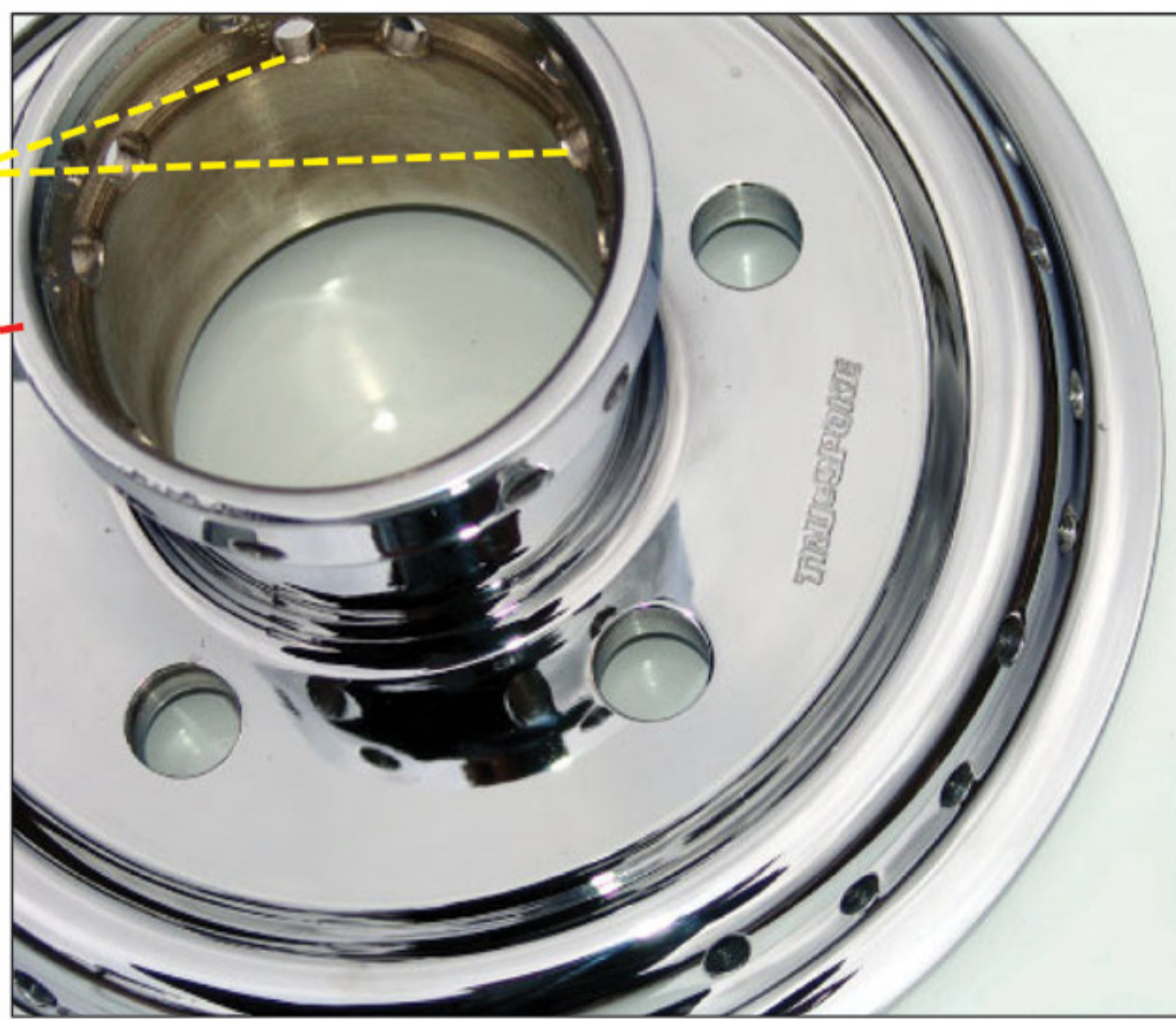

Modern Truespoke Hub Close-Up

Vintage Truespoke Hub

Three-piece hub is hand-welded together with uneven and crude-looking surfaces. Edges and surfaces do not have precision look.

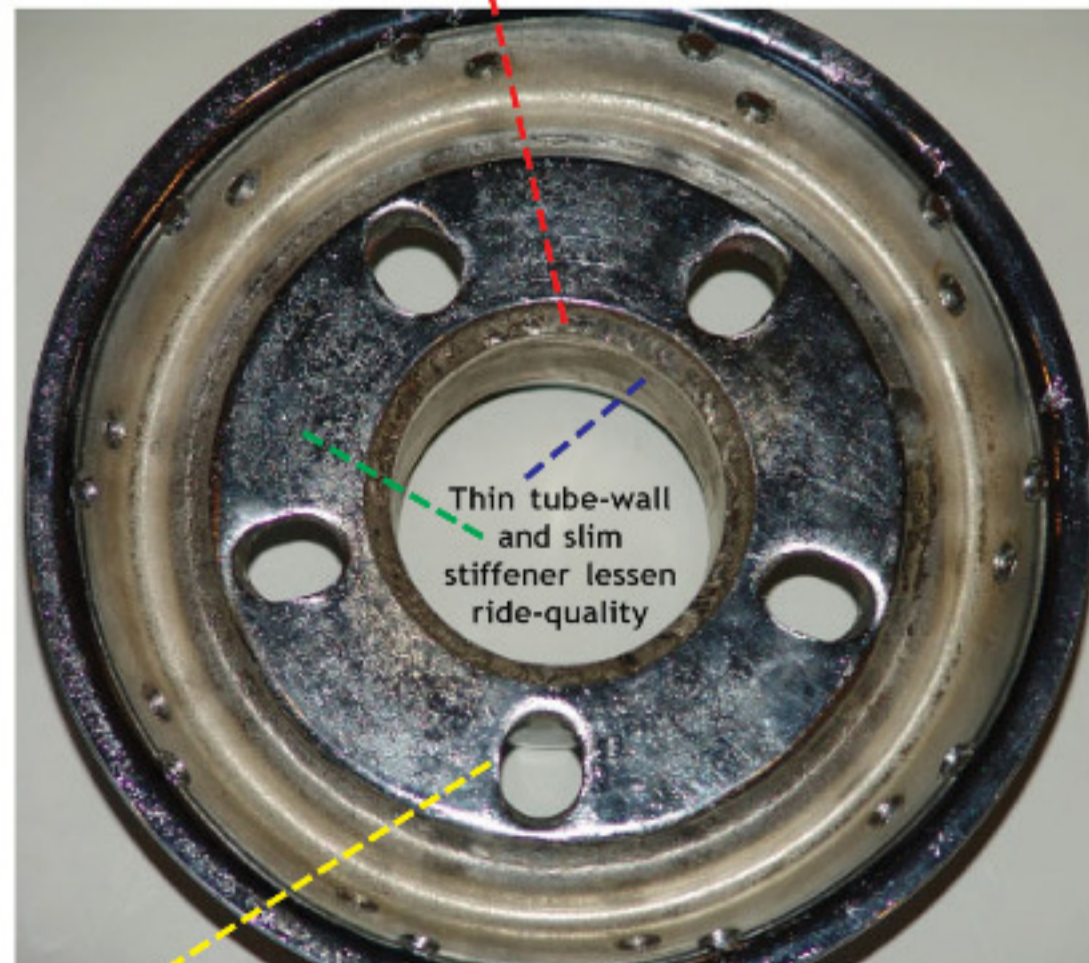

Outdated "Uni-lug" stud holes require special oblong washers and can contribute to vibration and harsh ride.

Precision smooth edges on one-piece forged steel hub

All surfaces machined smooth and polished

Thin tube-wall and slim stiffener ride-quality

• With restoration costs approaching or exceeding the cost of modern Truespoke wire wheels, it is hard to make a case for not purchasing brand new Truespokes. The upgrades and changes shown on this page provide compelling proof that the new Truespoke wheel is highly improved. The proof-of-the-pudding will be in the performance and beauty that your new Truespokes will provide.

• Our chrome-plating is performed here in Southern California by one of America's top chrome platers. Show-quality is a term we don't use lightly. You will be proud of the concours quality appearance and quality of these wheels.

• Our outer-rims are made by the same good folks who bring you Cragar wheels.

• Our assembly methods are as precision as possible for a wire wheel that is built entirely by hand in Southern California. We employ strict tolerances in the assembly of the wheel to improve ride quality and ease in balancing.

• No longer a mass-produced wheel as in the past, today's Truespoke is a quality wire wheel that thousands of owners are passionate about.